

DOUBLE DRUM ROTARY CUTTERS

TF 200 - 400 - 600 - 800 - 1000 - 2000 - 3000



WE DESIGN
CUSTOMER SATISFACTION.

- ✔ Ideal for trench cutting on hard and compact materials, concrete or rock wall profiling, quarry works, demolitions and dredging.
 - ✔ Indispensable in cases of excessive ground weakness of excavation systems where hammers are ineffective.
 - ✔ Designed for excavator mounting.
 - ✔ Producing small diameter spoil.
 - ✔ Low noise and environmentally friendly.
-
- ✔ Internal hydraulic piston motor and direct drive rotary cutters FOR MAXIMUM EFFICIENCY and minimum non-operational space between cutters.
 - ✔ SIMEX HIGH STRENGTH PATENTED DRIVE SHAFT DESIGN is not subject to the working stress of the rotary cutters, which are independently supported by long life bearings.

SIMEX
PATENT

Hydraulic motor

Support bearings

Drive shaft

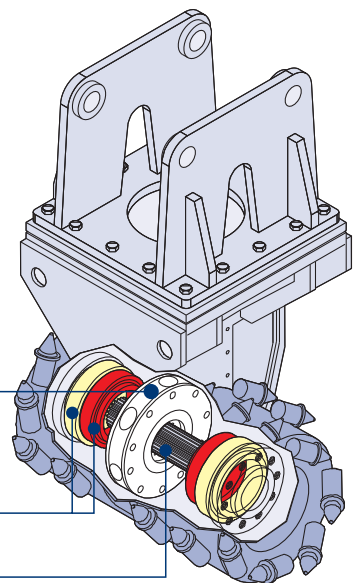

- ✔ Planing rotation, with hydraulic locking every 30°, for an easy orientation of rotation axis in all operation conditions (optional).



SECTIONS TRENCHES



In presence of rock and compact material, possibility to go deep without widening the trench, assuring normal traffic. The spoil is made up of small pieces. Ready for reuse on the worksite. So saving time and money.



QUARRY APPLICATIONS



Producing homogeneous small diameter spoil, ready for use.



WALL PROFILING



Demolitions and rough wall profiling, even with bracing, without damage to adjoining buildings.

DEMOLITIONS



It permits a precise partial or total demolition of buildings, walkways and floors.
Low vibrations transmitted to the surrounding area.



WORKS ON ROCK



Breaking rock walls, non-invasive for the environment.

Operations that permit safety and precision.



GALLERY OPERATIONS

Vast advantages in restricted space:

- low noise,
- environmentally friendly,
- little dust.

And extreme precision in finishing operations.



WE DESIGN
CUSTOMER SATISFACTION.

STRIPPING AND REDEVELOPMENT

6



Production of small diameter spoil that:
- for redevelopment operations does not require to be cleared away;
- for stripping is easy to remove and be re-used.

UNDERWATER WORKS



Operations in complete dive at considerable depth, preserving the environment.



TECHNICAL DATA

	TF 200	TF 400	TF 600	TF 800	TF 1000	TF 2000	TF 3000	
A (standard drums)	565	625	700	800	900	1100	1300	mm
A (profiling drums)	650	750	850	1000	1200	1400	1400	mm
B	380	450	500	590	660	710	740	mm
C	740	860	900	1100	1200	1400	1770	mm
D	75	75	75	110	110	125	110	mm
E	110	130	130	150	160	175	270	mm
Excavator weight (1)	2,5 - 7	6 - 12	9 - 16	14 - 22	20 - 34	28 - 45	40 - 60	ton
Hydraulic motor power	27 - (37)	37 - (50)	50 - (68)	61 - (83)	87 - (118)	112 - (152)	165 - (225)	kw (cv)
Required oil pressure (2)	350 - 200	350 - 200	350 - 200	350 - 200	350 - 210	400 - 210	400 - 210	BAR
Required oil flow (3)	45 - 80	65 - 120	90 - 150	105 - 190	150 - 250	170 - 340	250 - 480	l/min
Planing rpm	130 - 200	125 - 160	90 - 140	75 - 115	60 - 105	60 - 100	50 - 80	RPM
Cutting speed	2,6 - 4,0	2,9 - 3,8	2,4 - 3,7	2,4 - 3,6	2,2 - 3,5	2,2 - 3,8	2,2 - 3,2	m/s
Max output torque	2,5	4,6	6,9	9,5	15,6	19,1	38,2	KNm
Max cutting force	13,5	20,3	27,6	31,8	47,3	53,9	103,2	KN
Weight (std drum)	305	483 - 970 (4)	672 - 1180 (4)	1355 - 1815 (5)	1615 - 2075 (5)	2540	4100	kg

(1) The user is responsible for checking that the prime mover meets the equipment's specifications and weight requirements.

(2) The cutting force decreases at the pressure and/or oil capacity reduces.

(3) Number of revolutions and cutting speed decrease as the oil capacity reduces.

(4) Total weight including rotation and wall profiling drums.

(5) Total weight including hydraulic lock mechanical rotation.

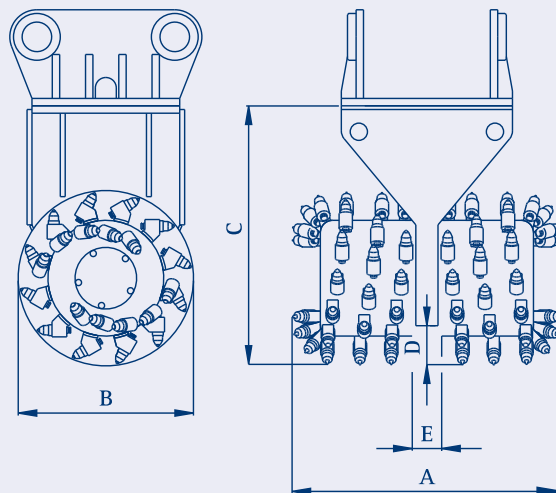

Standard drum



Drum for wall profiling



Drum for soft material

Materials and specifications liable to change without prior warning.
The equipment illustrated can be fitted with further equipment
and accessories available on request only. SKMCO08A08



WE DESIGN
CUSTOMER SATISFACTION.